

LOC	DIST	REVISIONS					
ES	00	P	LTN	DESCRIPTION	DATE	DWN	APVD
		A		RELEASED PER EC 0S13-0001-04	23JAN04	JG	JK
		B		REVISED PER ECO-06-008548	13APR06	BM	EB
		C		REVISED PER ECR-07-018402	19DEC2007	SL	SY
		C1		REVISED ECR-08-013764	30MAY08	AZ	SY

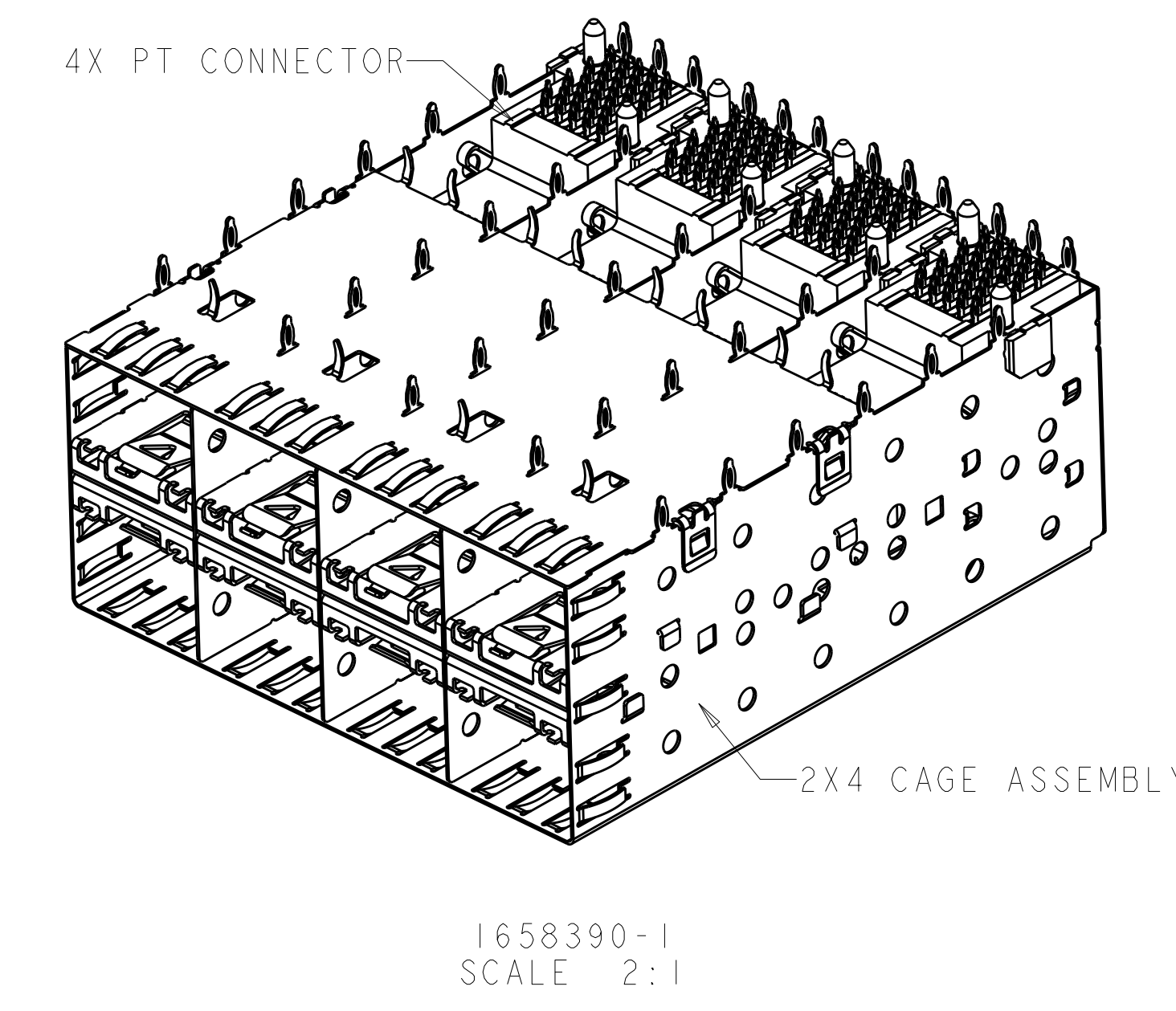
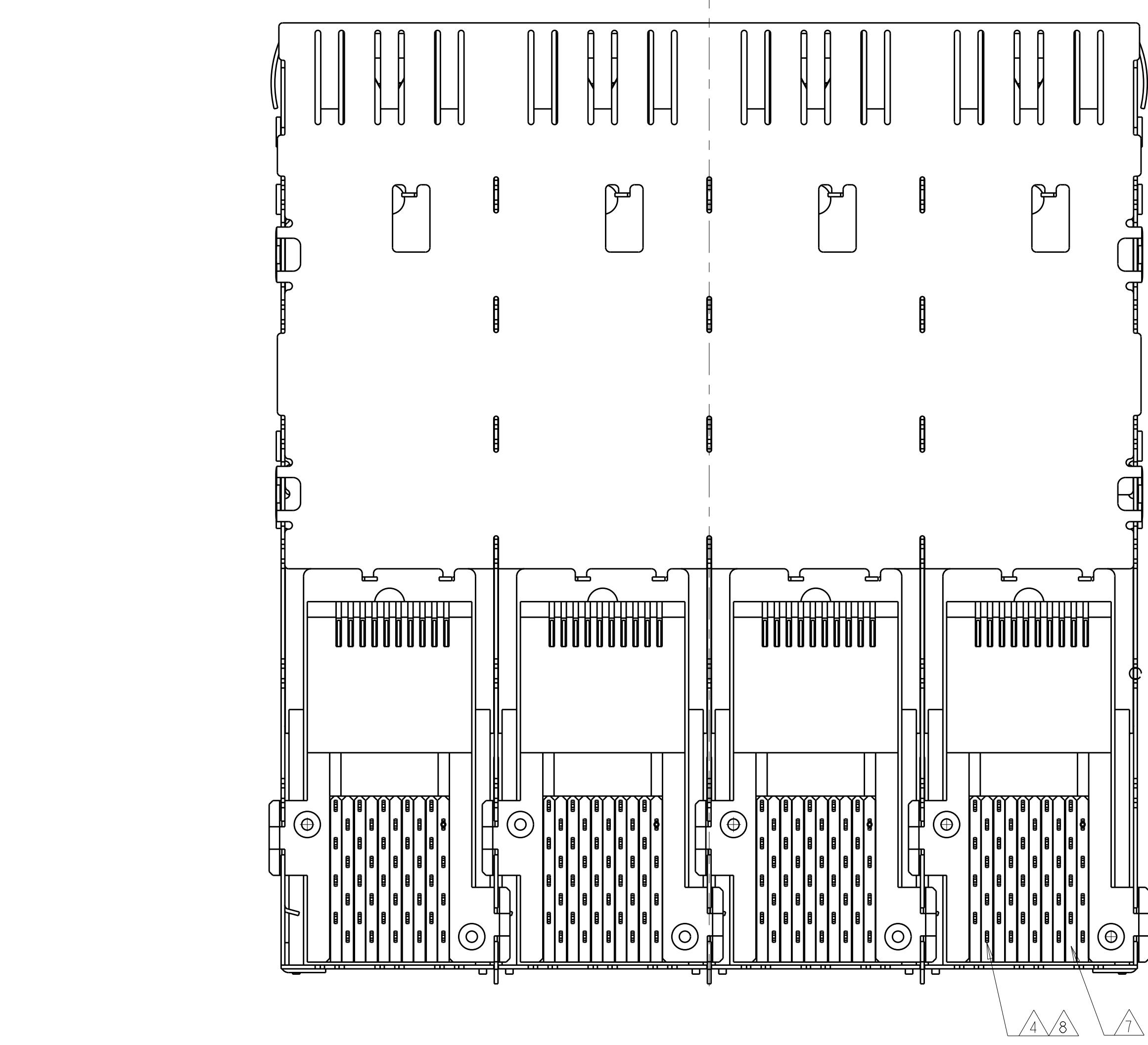
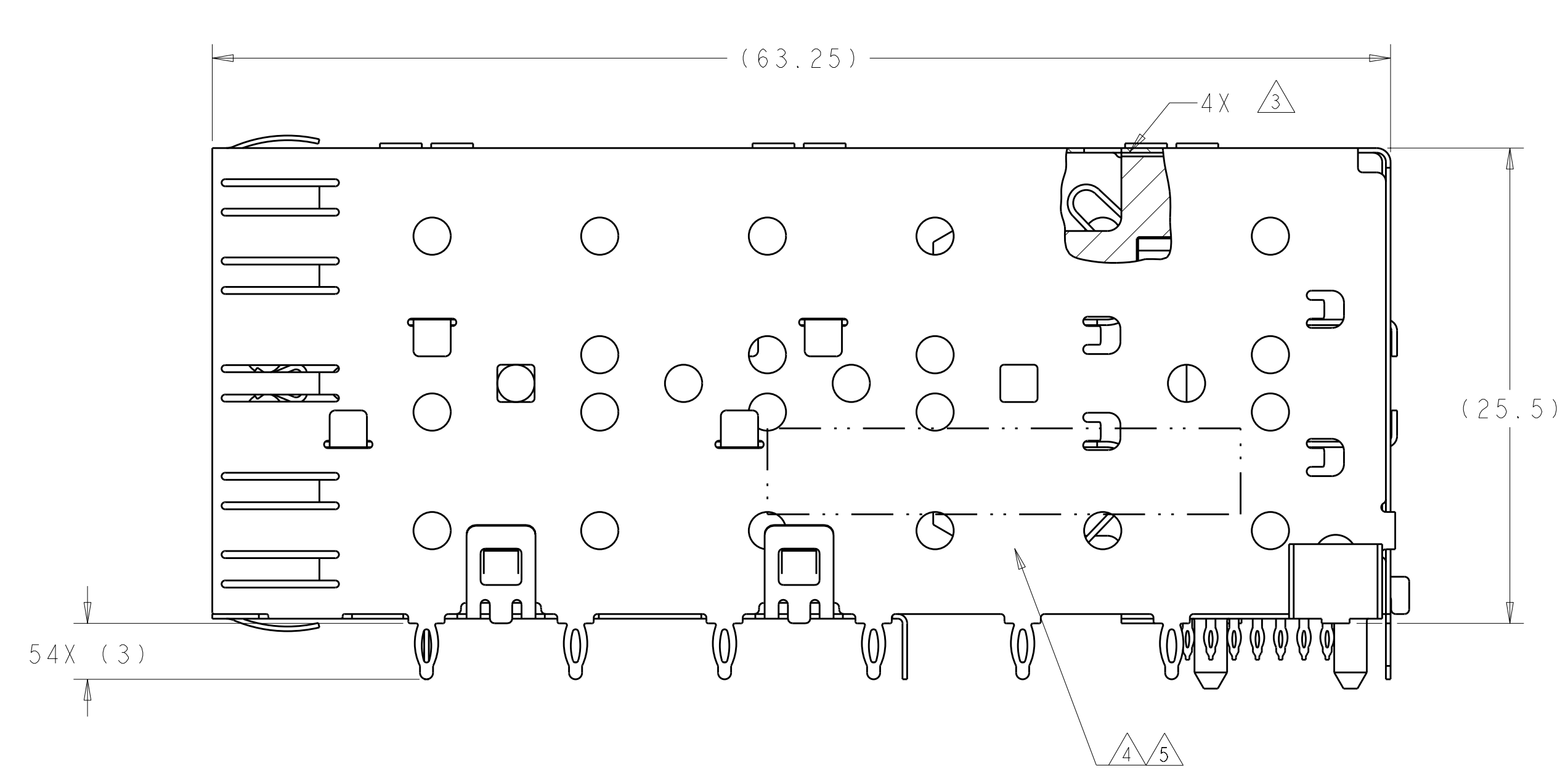
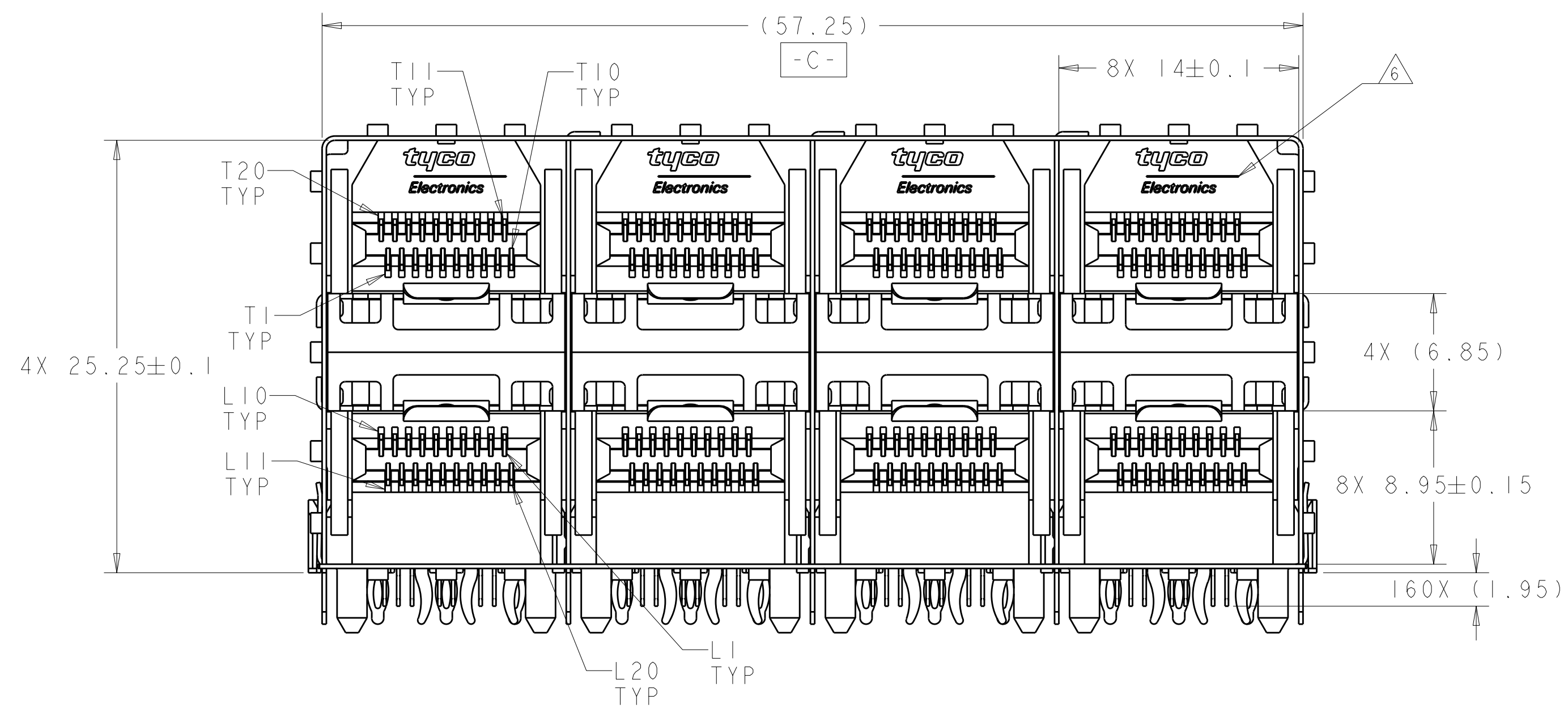

- ▲ DATUM AND BASIC DIMENSION TO BE DETERMINED BY CUSTOMER.
- ▲ INTERPRETATION OF DATUM REFERENCE FRAME IN ACCORDANCE WITH SECT 4.4.1.1 OF ASME Y14.5M-1994.
- ▲ TOP OF PT CONNECTOR TO BE 0-0.15 FROM INSIDE SURFACE OF CAGE.
- ▲ COPPER ALLOY.
- ▲ 1.25µm MIN TIN PER ASTM B 545 OVER NICKEL FLASH PER QQ-N-290. NON-PLATED EDGES PERMISSIBLE.
- ▲ LCP, HIGH TEMPERATURE, UL 94V-0 RATED, BLACK.
- ▲ POLYESTER, UL 94V-0 RATED, BLACK.
- ▲ CONTACT MATING AREA: SURFACE TREATMENT OVER 0.76µm MIN GOLD PER ASTM B 488 OVER 1.27µm MIN NICKEL PER QQ-N-290. NEEDLE EYE: 1.25µm MIN TIN PER ASTM B 545 OVER 1.27µm MIN NICKEL PER QQ-N-290. REMAINDER OF CONTACT: 0.76µm MIN NICKEL PER QQ-N-290.

1658390-1
PART NUMBER

DIMENSIONS: mm 9 PLC ± 1 PLC ±0.1 5 PLC ± 4 PLC ± ANGLES ±		TOLERANCES UNLESS OTHERWISE SPECIFIED: FINISH: -		DWN: M. COWHER 24MAR03 CHK: J. KOPPENHEFFER 23JAN04 APVD: M. WALMSLEY 23JAN03		Tyco Electronics Shanghai, China	
MATERIAL: - FINISH: -		PRODUCT SPEC: 108-2161 APPLICATION SPEC: 114-13103		NAME: PT CONNECTOR AND CAGE ASSEMBLY, 2x4, PRESS FIT, STANDARD PROFILE, SFP		SIZE: A1 CAGE CODE: 00779 DRAWING NO: C=1658390	
CUSTOMER DRAWING				SCALE: 4:1		SHEET 1 OF 3 REV. C1	

LOC	DIST	REV	DATE	BY	APPD
ES	00				
		REVISIONS			
		DESCRIPTION	DATE	BY	APPD
		SEE SHEET 1			

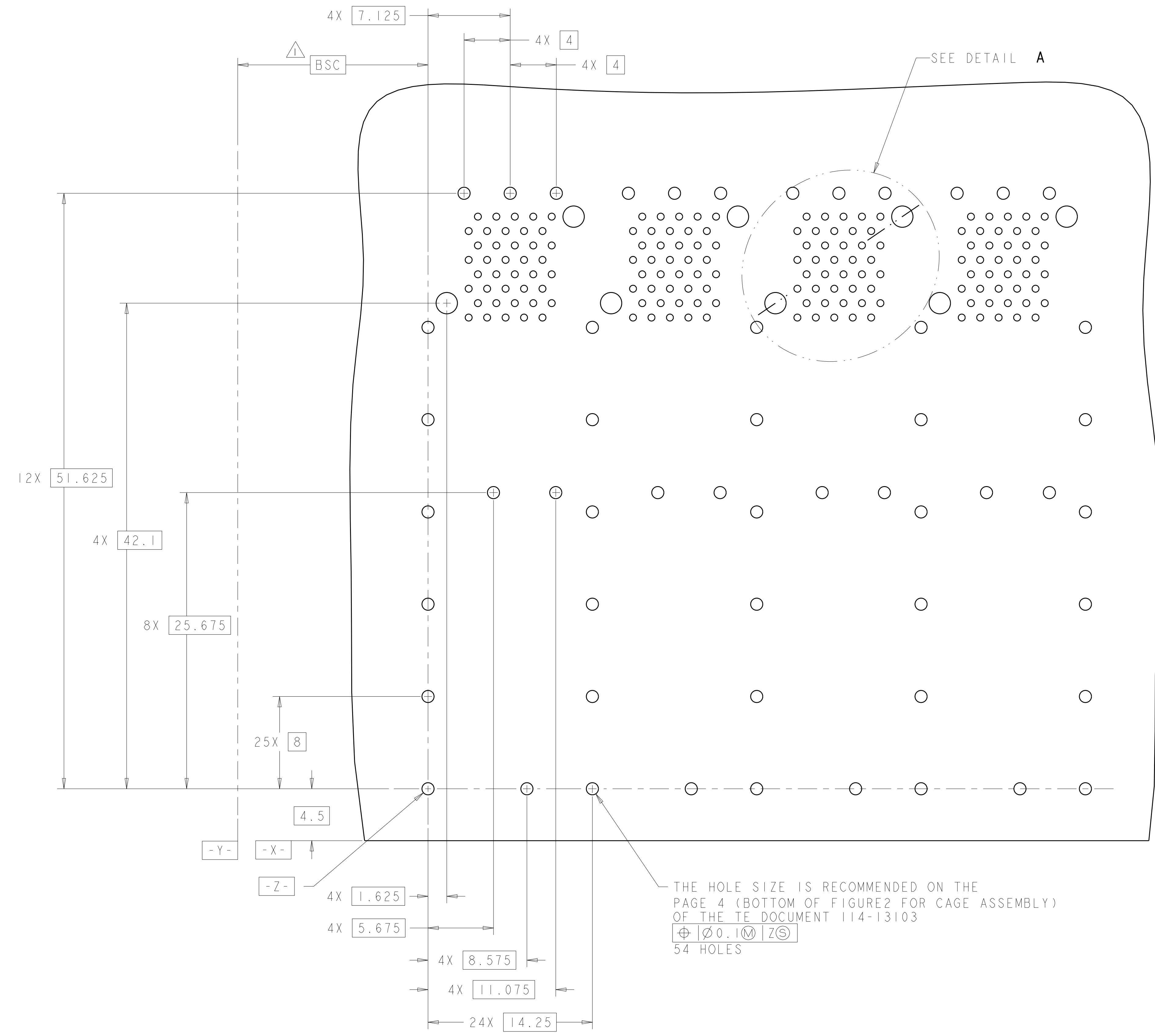

THE HOLE SIZE IS RECOMMENDED ON THE
 PAGE 4 (BOTTOM OF FIGURE2 FOR CAGE ASSEMBLY)
 OF THE TE DOCUMENT 114-13103
 $\varnothing 0.10 \text{ (M)} \text{ (Z)} \text{ (S)}$
 54 HOLES

RECOMMENDED PCB CONFIGURATION
 SCALE 5:1

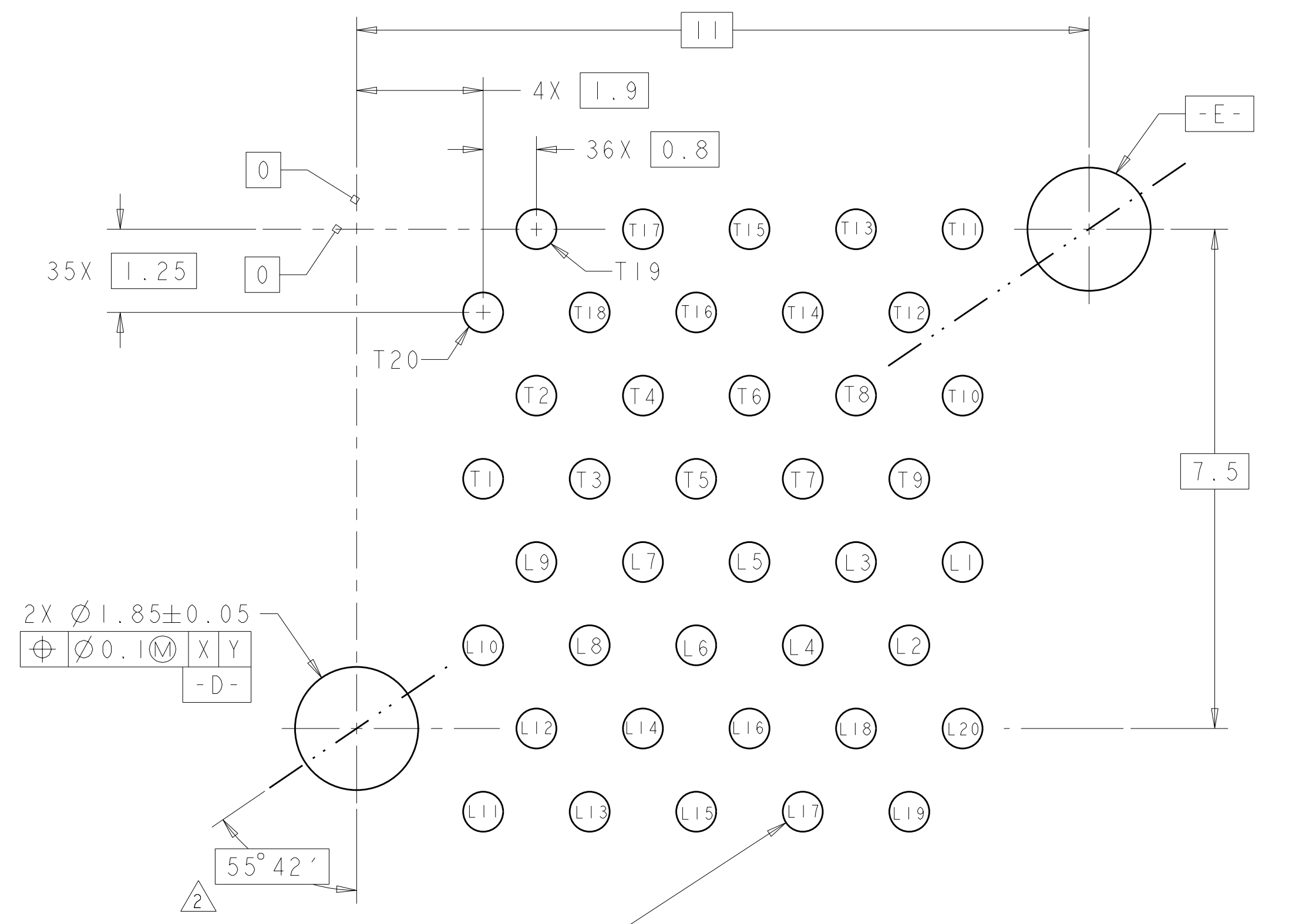

DETAIL A
 SCALE 15:1

<small>THIS DRAWING IS UNPUBLISHED. RELEASED FOR PUBLICATION BY TYCO ELECTRONICS CORPORATION. ALL RIGHTS RESERVED.</small>		DWN: M. COWHER 24MAR03 CHK: J. KOPPENHEFFER 23JAN04 APPD: M. WALMSLEY 23JAN03	Tyco Electronics Shanghai, China
DIMENSIONS: mm 	TOLERANCES UNLESS OTHERWISE SPECIFIED: 9 PLC ± 1 PLC ±0.1 5 PLC ± 4 PLC ± ANGLES ±	NAME: PT CONNECTOR AND CAGE ASSEMBLY, 2x4, PRESS FIT, STANDARD PROFILE, SFP PRODUCT SPEC: 108-2161 APPLICATION SPEC: 114-13103 WEIGHT: - CUSTOMER DRAWING	SIZE: A1 CAGE CODE: 00779 DRAWING NO: C=1658390 RESTRICTED TO: - SCALE: 4:1 SHEET 2 OF 3 REV: C1

LOC	DIST	REV	DATE	BY	APPD
ES	00	-	-	-	-
DESCRIPTION			DATE	DWN	APPD
SEE SHEET 1			-	-	-

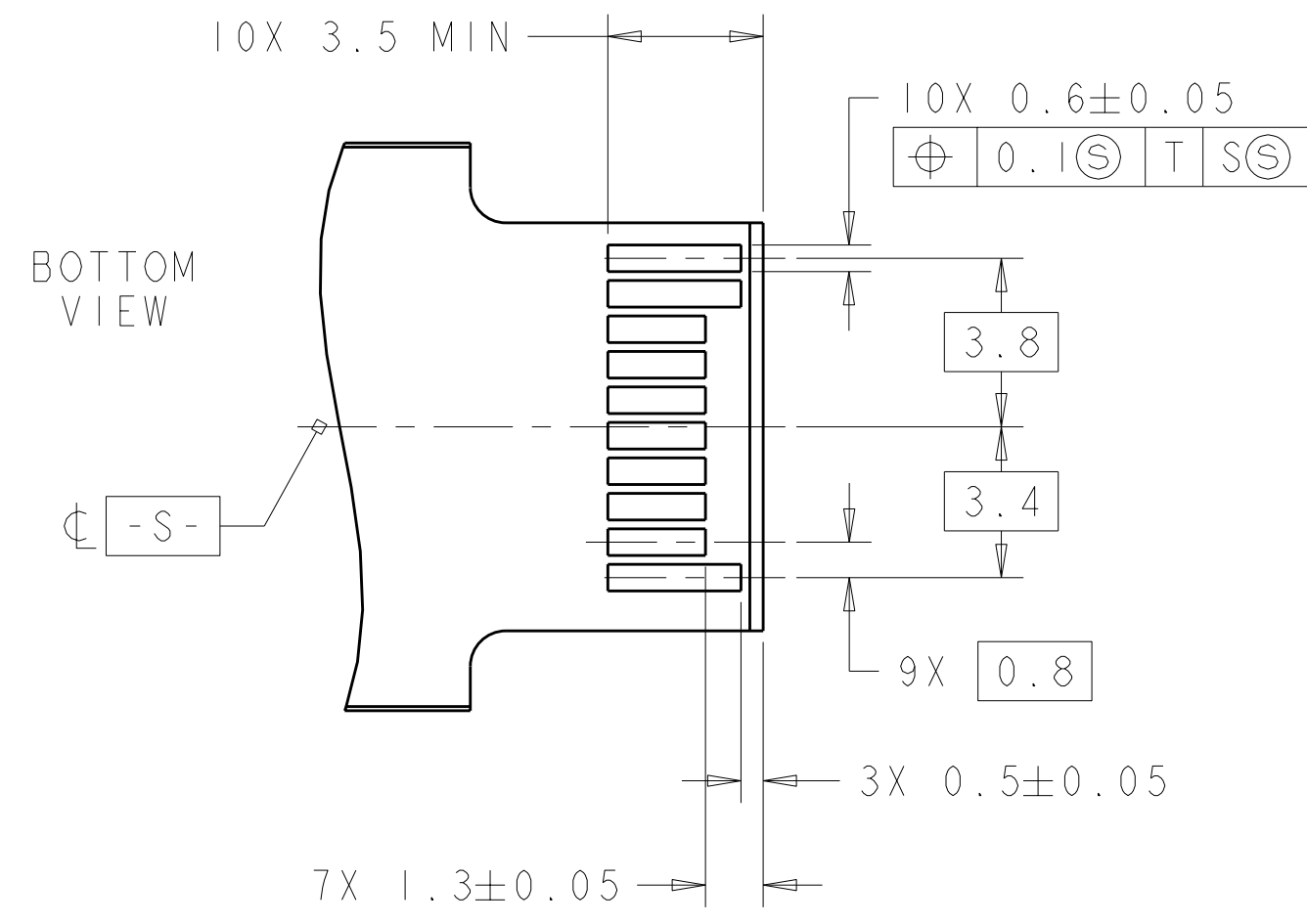
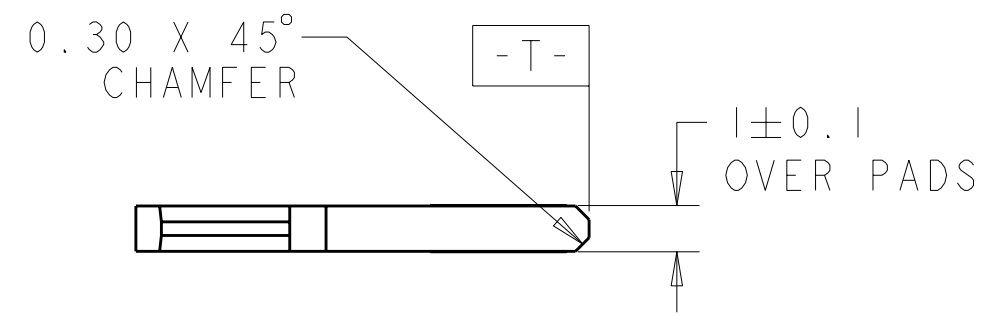
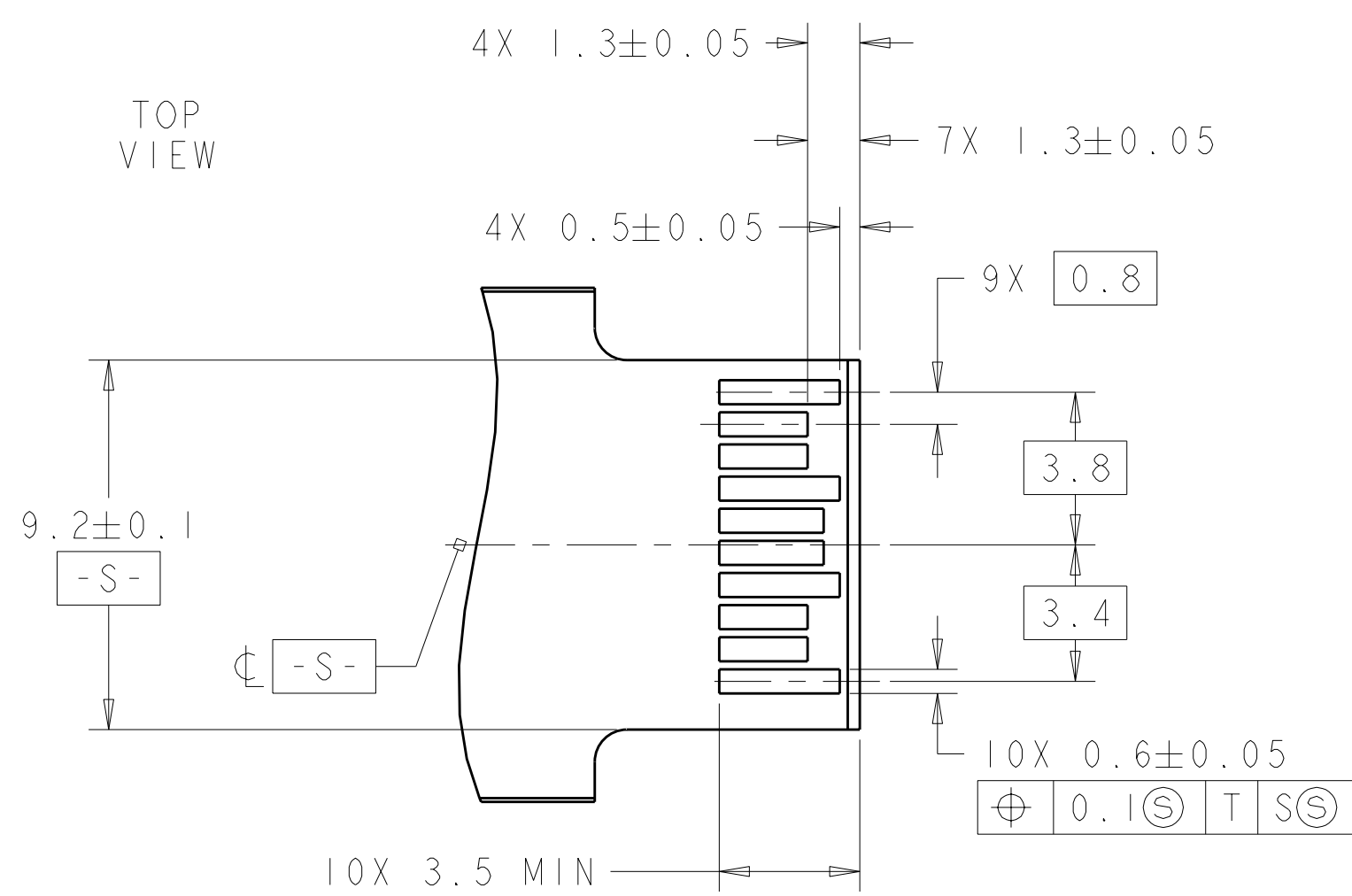

RECOMMENDED LAYOUT FOR
 MATING TRANSCEIVER PCB
 SCALE 6:1

<small>THIS DRAWING IS UNPUBLISHED. RELEASED FOR PUBLICATION 20. THIS IS SUBJECT TO CHANGE WITHOUT NOTICE AND WITHOUT OBLIGATION. SHOULD BE CONTACTED FOR THE LATEST REVISION.</small>		DWN M. COWHER 24MAR03 CHK J. KOPPENHEFFER 23JAN04 APPD M. WALMSLEY 23JAN03	Tyco Electronics Shanghai, China
DIMENSIONS: mm 		TOLERANCES UNLESS OTHERWISE SPECIFIED: 9 PLC ± 8 PLC ±0.1 5 PLC ± 4 PLC ± ANGLES ±	NAME PT CONNECTOR AND CAGE ASSEMBLY, 2x4, PRESS FIT, STANDARD PROFILE, SFP PRODUCT SPEC 108-2161 APPLICATION SPEC 114-13103 WEIGHT - CUSTOMER DRAWING
MATERIAL - FINISH -		SIZE A1 CAGE CODE 00779 DRAWING NO. C=1658390	RESTRICTED TO - SCALE 1:1 SHEET 3 OF 3 REV C1